



PRODUCT DESCRIPTION:

Mobile Storage Carts are available in a variety of configurations to compliment any environment.

See our [Finishes](#) page for Laminate options.

FEATURES:

Custom drawers can be sized to spec

Available with attached countertop

Freestanding or mobile units with casters available

Standard with randomly-assigned LL Series locks, UM locks are available as an option and are black-faced, master-keyed, and core-removable

Locks may be keyed-alike in the field

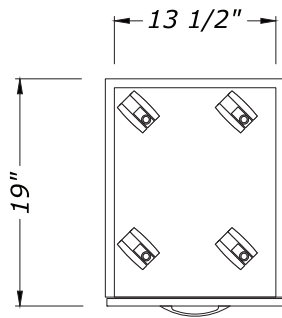

PLAN VIEW

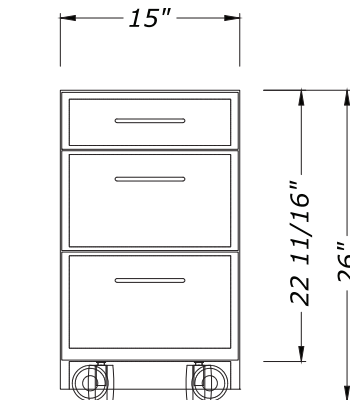

FRONT VIEW

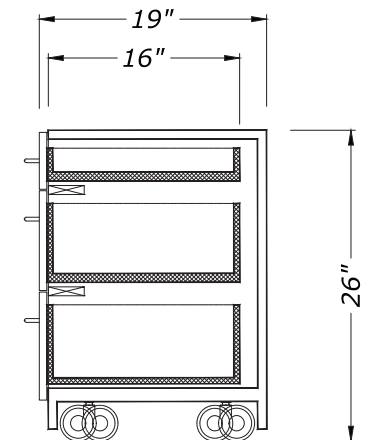

SECTION VIEW